

Shinpo was the first in the world to develop a smokeless grill that is durable with high heat.



Shinpo Smokeless Electric Grill

# SERW-CE

Compliant with  
EU Safety Standards



Shinpo electric grills are friendly to both the global environment and employees. **Zero CO<sub>2</sub> emissions**

### Reason 1

Less possibility for employee injury

### Reason 2

Easy to clean

### Reason 3

Fewer parts. All parts more durable

### Reason 4

Thorough electric shock prevention measures. Thorough waterproofing measures

### Reason 5

Less construction costs compared to gas.

### Reason 6

Less construction costs compared to gas.

### Reason 7

Less expensive than gas models.

### Reason 8

More reliable.

### Reason 9

Easy to operate.

### Reason 10

No uneven cooking.

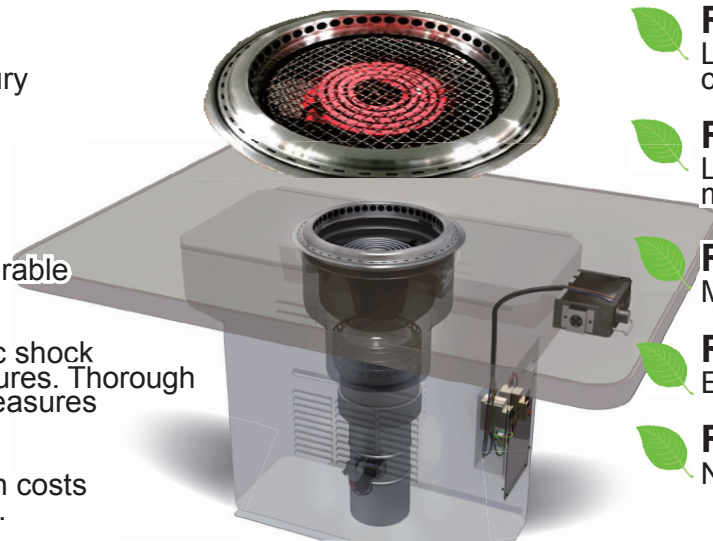

<b>Standard:</b> LVD: 2014/35/EU EMC: 2014/30/EU	<b>LVD Directives:</b> EN 60335-1 EN 60335-2-36
<b>Rating:</b> 220~240 Vac, 50/60 Hz, 2000 W,	<b>EMC Directives:</b> EN 62233 EN 55014-1 EN 55014-2 EN 61000-3-2 EN 61000-3-3

**Safety, security and delicious grilling, all combined.**  
**The smiles of happy employees adds to the total experience.**

When the grill is substandard, there is a downward spiral. Employees get stressed, the staff burns out; work becomes a chore; customers receive uneven service; employee smiles turn into frowns; employees quit in frustration; customers are no-longer happy; the restaurant's popularity declines; and, sales suffer. Employees play a critical role in the success of a Yakiniku restaurant; it's not just the quality of the meat and sauce.

**Here are some of the reasons why smart restaurateurs choose Shinpo Electric Smokeless Grills.**







- |   |   |
|---|---|
| #1 Employees often get burned or injured on the job. This situation leads them to quit. They mostly cite equipment that is dangerous or difficult to use as the reason. | #6 Deteriorating gas pipes can be an issue. Construction costs are reduced by switching to electric.                                |
| #2 Cleaning is bothersome and tiring. Employees just don't like to clean.   | #7 The landlord does not like gas systems. They start to worry about the possibility of fire.                                       |
| #3 Parts often break, and it's difficult to find replacement parts  | #8 Equipment failures can lead to tables being out of commission. Financial losses are hard to recover.                             |
| #4 Water leaks can cause breakdowns   | #9 Gas-type grills often require frequent heat adjustment which is very inconvenient.   |
| #5 There has been a recent increase in fire incidents. This is a cause of great concern.  | #10 Shinpo's electric Smokeless grills are the right choice for cooking quality and consistency. Their reputation is well deserved. |

**Product information / Maintenance / Repair / Troubleshooting**

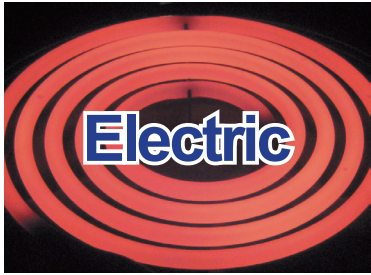
**Smokeless Grill Corp.** inquiryen@shinpo-en.com Tel +1-925-223-8673 Fax +1-925-223-6568

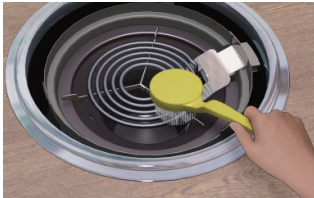
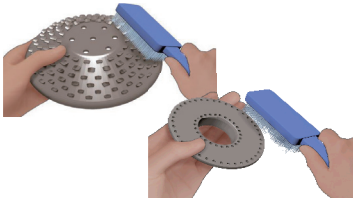
## Shinpo was the first in the world to develop a smokeless grill

# Gas vs. Electric Grills: Pros and Cons

			
Cost	30% cheaper than gas type	30 to 40% higher than electric type	Electric type and approximation
Heat	Cooking surface: 210~255°C	Cooking surface: 200-250°C (SPRW) 235-280°C (SKRW)	Cooking surface: 215-220°C
Clean up	Cleaning the electric heating coil is easy with a brush. 	Difficult to clean grime out of gas burner holes. 	There are fewer surfaces to clean. Employees do not want to clean the ash receptacle when there are sparking embers. 
Burden on Employee	Since there is only one electrical switch, it is easy to operate. There is no need to worry about flare-ups or burn-outs. 	Having to adjust the temperature too often. Too much back-and-forth. Reasons employees quit the job. Ignition failures and gas leakage due to clogging grime. 	Transporting and installing charcoal can cause burns. Two staff members are required for the charcoal operation, increasing costs. Customers often get burned by sparks and ash from the fire. 
Store Contract	More advantageous for obtaining tenant contracts within skyscrapers, shopping malls and luxury hotels. Easier to get a building permit and fire permit.	Disadvantages to tenant contracts. Concerns about uncontrolled fires and explosions. It is more difficult to obtain a building permit or fire permit; takes a longer time. Greater safety regulations apply.	Disadvantages to tenant contracts. Concerns about uncontrolled fires and explosions. It is more difficult to obtain a building permit or fire permit; takes a longer time. Greater safety regulations apply.
Construction Costs	\$313K- ---	\$377K- \$64,000 for gas pipe and alarm system	\$XXX ---
Utility Costs	\$3,920	\$2,219	\$8,159 High charcoal costs

Price: Comparison by Shinpo product. Construction cost: 20 stores (Manhattan, NY city) Utility cost: 20 grills, 45 minutes per rotation, 3 turnovers per day.

### The service staff is the heart and soul of a Yakiniku restaurant.

It is very important to reduce the burden of daily cleaning and the back-and-forth to adjust the heat.

The grease catchers below only require washing once per day, at closing.

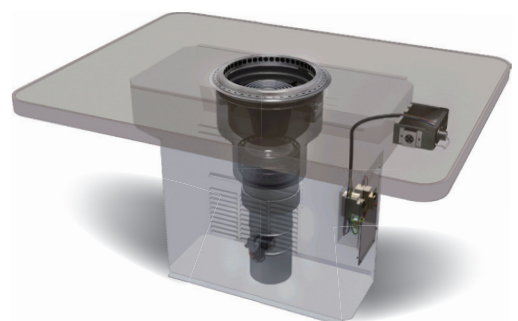

### Product information / Maintenance / Repair / Troubleshooting